

# Face Recognition Product F0808

## User manual



Bozz Technology(Shenzhen) Co.,Ltd

Release Version:V1.1

Date:2020.05.27

## Description of Face Recognition Terminal F0808

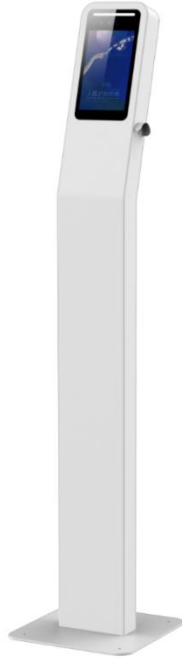

### I. application scenarios

Applicable to office areas, hotels, office buildings, schools, shopping malls, stores, communities, public services and other places that require access control privileges, human verification management.

### II. product characteristics

- Wide dynamic binocular camera, supports live monitoring;;.
- Efficient infrared fill light.
- Single-point temperature monitoring function module.
- Optional human movement detection module.
- Optional external NFC card reader, ID card reader, sunshade.
- Support RS-485 serial port, standard Wegen interface, built-in relay, multiple I/O inputs and outputs, door magnetic output.
- Support the use of public network, LAN deployment mode, optional 4G communication module.

### iii. Product specification sheets

Integrated Face Recognition Terminal			
Product Model Number		F0802-PLUS	
Screen	Dimensions	8 inches Full View	
	Resolution	800*1280	
Camera	Type	Color	Infrared
	Resolution	2 megapixels	1.3 megapixels
	Aperture	F2.4	F2.4
	Focal length	3.0MM	3.0MM
	White balance	Automatically	Automatically
	Wide Dynamic	Support	Support
	Vertical wide angle	88°	88°
	Horizontal wide angle	57°	57°
basic specifications	operating systems	Android 7.1 BOZZ OS	
	Processor	3288 A17*4 at 1.8GHz & Mali T764 Optional Configurations:RK3399 A72*2+ A53*4 1.8GHz & Mail T864	
	Memory	2G DDR+32G EMMC Optional:4G DDR+16G/32G/64G EMMC	
	equipment power supply	AC 100-220V	
	equipment power consumption	15W Max	
	relative humidity	0%-90% (in non-condensing state)	
	Operating Temperature	-10°C ~ 55°C	
	Storage temperature	-20°C ~ 70°C	
	level of protection	IP54	
	the environment in which it is used	Indoor, semi-outdoor	
	equipment dimensions	Adult version 295*295*1344.7mm (Child version 295mm*295mm*944.7mm)	
identification method	face/temperature measurement/code scanning/NFC		
	Interface	USB Type-A *1	
		RJ45 LAN port*1	
		Micro-USB debugging port*1 (built-in)	
		AC power port*1	
		RS485*1 (built-in)	
		Relay switch interface*1 (built-in)	

hardware configuration		Standard Wergen interface*1 (built-in)
		I/O ports*2 (built-in)
		SIM card slot*1 (built-in)
	Infrared fill light	Support
	Two-color status indicator light	Support
	White filler light	Support
	temperature monitoring	Support
	Speakers	3W*1
Basic parameters	WIFI	2.4G Support IEEE 802.11b/g/n
	Bluetooth	Support Bluetooth 2.1/3.0/4.0/4.2
	means of communication	4G Full Netcom(Optional:Customized purchase required)
packaging parameters	Weight	Net weight 12.0Kg, packing weight about 16Kg; (Children: net weight 9.5Kg, packing weight about 13Kg)
	Dimensions	345*345*1400mm(Children's version 345*345*1000mm)

#### IV.F0808 Terminal Type Diagram

①Adult version.



②Children's Edition.



**V. F0808 access control machine external dimensions**

①Adult version shape and size (295\*295mm\*1344.7mm)

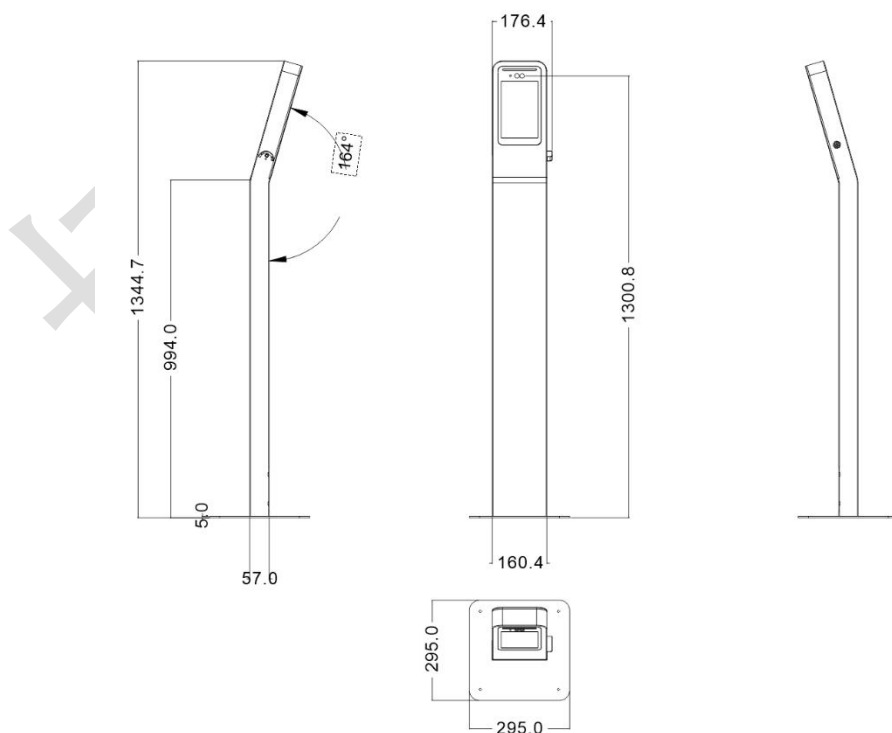

②Children's version shape and size (295mm\*295mm\*944.7mm)

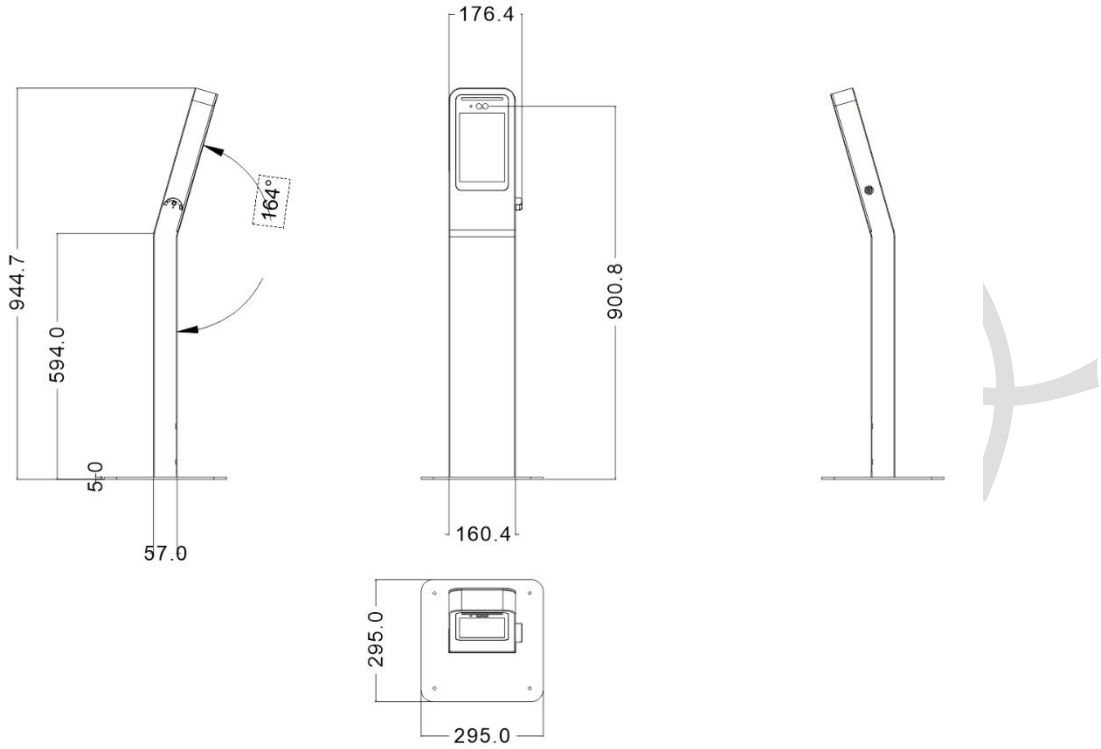

**VI. Exterior part indication and wiring instructions**

(i) Description of the front part of the access control machine

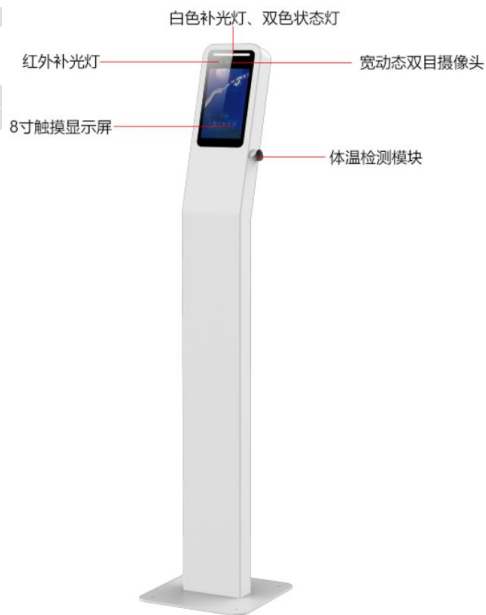

(ii) access control integrated wiring harness wiring instructions

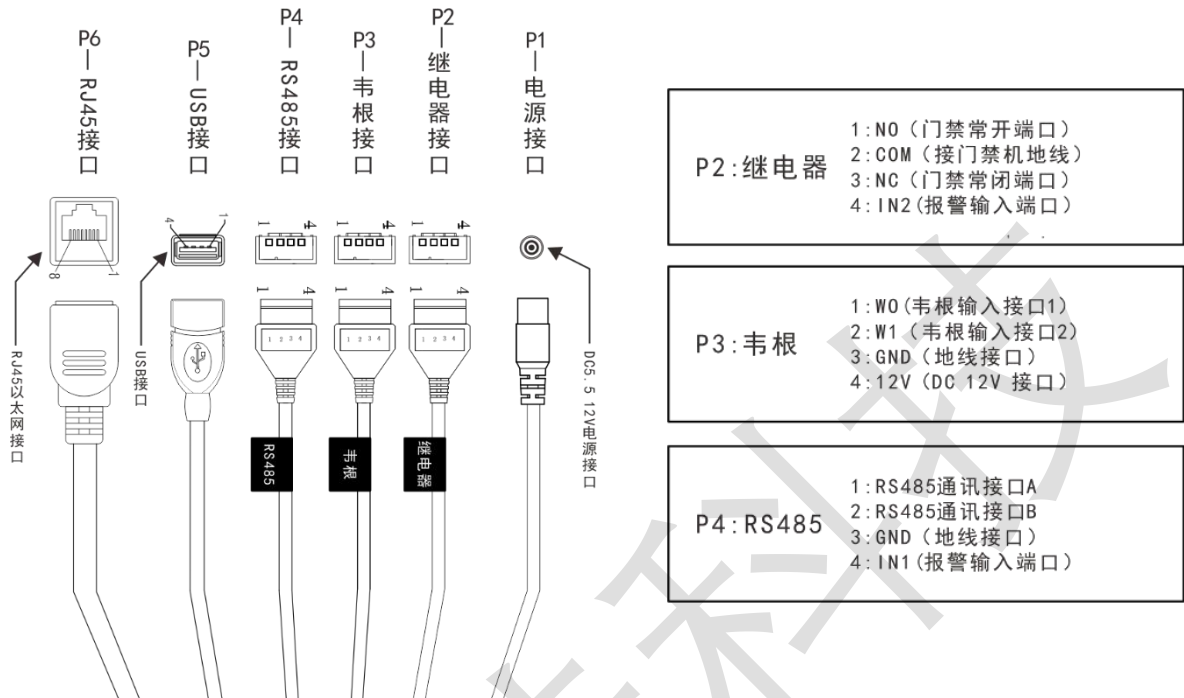

**Points to note.**

- 1, relay interface control access control on and off (similar to the switch), itself can also be powered.
- 2、 Weingart interface meets the input and output signals corresponding to Weingart protocol, and W0 and W1 are used as a group, and cannot be used individually by W1 or W2.
- 3、 RS485 interface can communicate with external access control corresponding RS485 interface.
- 4, alarm input port (IN1/IN2) is a selective connection port, can also be turned into an output port, according to the need to choose to connect or not connect, does not affect the use.

**VII. Installation steps**

(i) F0808 Installation of Facial Recognition Thermometry Access Control

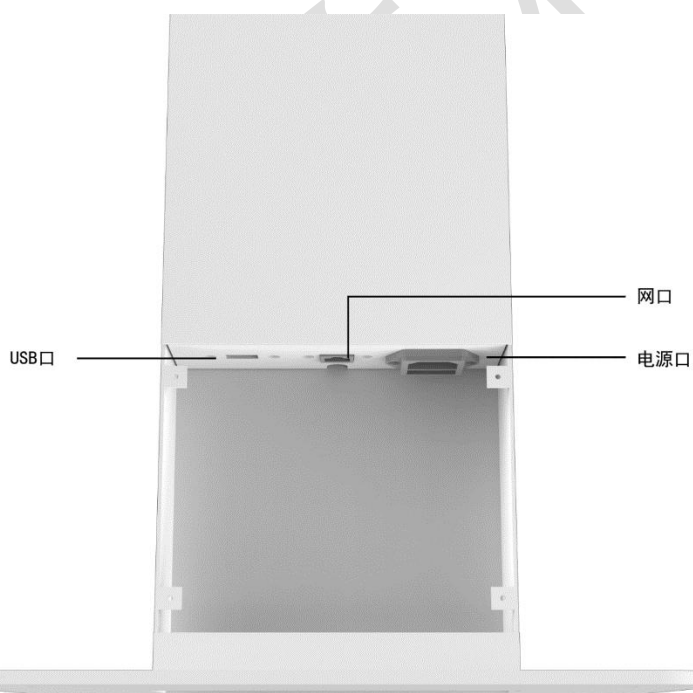
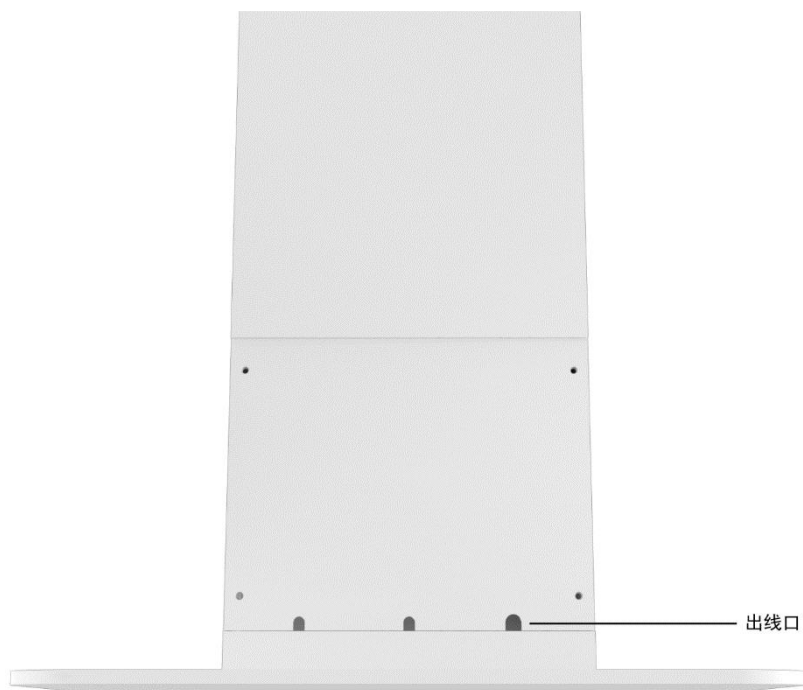

**Note: Open the interface anti-dumping cover and connect the wires directly.**

## **VIII. Packaging of access control machines and instructions for use**

### **(i) List of materials/tools**



Serial number	Name of material/tool	Dosage	Description
1	Mainframe and self-contained accessories	1	The accessories include: AC power cord, accessory screws, desiccant, warranty card, inspection certificate, packing list and so on.
2	Outdoor switch (optional: requires outsourcing)	1	For use when going out (if you already have one, you don't need another one)
3	Electromagnetic lock (optional: to be purchased)	1	Power off to open the door, power on to lock the door (if you already have, do not need to match)
4	Magnetic lock power supply (optional: need to be purchased)	1	Power is supplied to the solenoid lock, and at the same time can be supplied to the Uface mainframe (not required if already in place)
5	Network cable (optional: to be purchased)	Several	for laying out Ethernet and other residual alignments
6	Network cable clamp, network tester, diagonal pliers, electrical tape, wire snap (optional: need to be purchased)	Several	for laying out Ethernet and other residual alignments
7	Drilling tools (optional: to be purchased)	Several	For installing equipment, wiring alignments

## IX. installation considerations

- 1, installation or wiring, check whether the local voltage is in line with the product, if necessary, turn off the electric switch, do not operate with electricity.
- 2, the installation process needs to be careful, moving the whole machine should be gently, and should be prepared to padding to prevent scratches on the display.
3. Non-professionals are not allowed to dismantle the machine.
- 4, the equipment built-in relay device, its magnetic lock (or other access control unit) load maximum voltage can not exceed DC12V, the maximum current can not exceed 2A, if more than the relay will break down, resulting in can not open the door.
- 5, the product is a precision device, avoid collision, drop, vibration, so as to avoid the main board components fall off or internal damage to the camera, resulting in functional problems or performance problems.
- 6, the use of the cable can not be too thin (such as network cable thin line), it is recommended that the parallel connection of multiple strands of the same cable or the use of copper cores to thicken the cable.  
 Note: If you use a network cable, use 4 strands of network cable as positive pole and 4 strands as negative pole for the extension cable.
- 7, must do a good job of anti-interference, to avoid strong electricity and strong electromagnetic fields. Such as electromagnetic appliances, cell phones and other electrical appliances can be moved at will should be as far away from the equipment.
- 8、 The chassis is reserved with fixing holes, which can be fixed with locking bolts.

## **X. Option specifications and installation instructions**

Development instructions for the optional human body temperature measurement module, the

### **Chapter 1: Introduction to Human Body Temperature.**

Generally speaking, excluding all kinds of diseases, especially colds and fevers and other illnesses, the human body temperature is constant, but only with the body type, some slightly higher, some slightly lower, basically can be maintained at 36 degrees or so. In fact, if seriously from the microscopic point of view, within a day, human body temperature is not constant, there is a slight difference, but the change is not big, not easy to be noticed. Let's learn more about this first.

In daily life, it is important to note that body temperature is not fixed, and that programs and changes are also factors that affect body temperature. It can also be said that the body temperature in life is relatively constant. Therefore, it is possible to check the body temperature in daily life to observe changes in the patient's condition and to anticipate certain diseases.

The temperature of the human body is relatively constant, normal people in 24 hours of body temperature fluctuations, generally not more than 1 degree difference. Under physiological conditions, the body temperature is slightly lower in the morning and slightly higher in the afternoon. After exercise, eating, before menstruation or during pregnancy, the temperature is slightly higher, while the temperature of the elderly is lower. Body temperature above normal is called fever, 37.3 ~ 38 degrees Celsius for low fever, 38.1 ~ 39 degrees Celsius for moderate fever, 39.1 ~ 41 degrees Celsius for high fever, 41 degrees Celsius or more for ultra-high fever. The relative constancy of human body temperature is one of the important conditions to maintain normal life activities, such as body temperature is higher than 41 degrees Celsius or lower than 35 degrees Celsius will seriously affect the functional activities of various systems (especially the nervous system), and even jeopardize the life. The body's heat production and heat dissipation, is regulated by the nerve center, many diseases can make the normal regulation of body temperature dysfunction and make the body temperature change. Clinical examination of the patient's body temperature and observation of its changes are important for diagnosis of diseases or to determine the prognosis of certain diseases.

Normal body temperature.

There are differences in body temperature between morning and evening, between different parts of the body and between men and women. Normal body temperature has a stable range, but it is

not constant. Normal human forehead surface temperature of about 35.0 °C ~ 36.6 °C, by the environment and the detection of the greater distance between the influence of the oral temperature (also known as oral temperature) for 36.2 °C ~ 37.2 °C, the armpit temperature than the oral temperature is lower than the temperature of 0.2 °C ~ 0.5 °C, rectal temperature (also known as the temperature of the anus) than the oral temperature is higher than the temperature of 0.2 °C ~ 0.6 °C. Throughout the day, 2 ~ 5 in the morning when the body temperature is the lowest, 5 ~ 7 in the afternoon when the highest, but the temperature difference within a day should be less than 0.8 °C. In addition, women's body temperature is generally higher than men's by about 0.35°C. Women's body temperature also changes slightly during menstruation, and the body temperature during pregnancy increases with the secretion of hormones.

In a healthy state, such as normal diet, appropriate clothing, the body temperature is generally relatively constant, that is, to remain in the 37 °C up and down (roughly between 36 °C ~ 37.2 °C), and not due to changes in the external environmental temperature changes. Normal body temperature in the average between 36 ~ 37 °C (armpit), beyond this range is fever, 38 °C or less is low fever, 39 °C or more is high fever.

From the above, it is easy to see that a person's body temperature is different in the morning and evening, day and night, and the temperature of various parts of the body is also different. So there are no absolutes in the world. With this knowledge, you can judge your own health condition. If you find a disease, you will be able to cooperate with your doctor for timely treatment. Therefore, the body temperature should not be ignored.

## **Chapter 2:Principles of Temperature Monitoring Function of F0808.**

F0808 is a high-performance, intelligent face recognition equipment with a wealth of expansion interfaces, it integrates binocular camera, and far-infrared temperature monitoring module, access control disconnect, Weingarten protocol, RS485 and other rich interfaces, the use of aluminum casing, beautiful and atmospheric, applied to face recognition access control, attendance, gates and other scenarios, in the face recognition at the same time as the temperature monitoring of the personnel.

Far infrared heat sensor principle: any object within the charged particles are in constant motion, when the object temperature is higher than the thermodynamic temperature 0 (-273 degrees Celsius),

it will continue to electromagnetic radiation to the surrounding. Objects of spontaneous radiation, room temperature is mainly infrared radiation, commonly known as infrared, it is invisible to the human eye light, has a strong thermal effect, it is also known as thermal radiation. Thermal radiation characteristics are mainly determined by the temperature, so it is called temperature radiation, is the basis of optical temperature sensing. F0808 is formally utilized to monitor the energy radiated by the human body to determine the temperature of the surface thermal equilibrium of the target object.

As introduced in the previous chapter, the human body's internal temperature is constant at about 37, according to the principle of thermodynamics, the human body through conduction, radiation, convection, evaporation of different ways in different temperatures and the environment to achieve thermal equilibrium to ensure that their own body temperature is constant, such as being blown by the wind will make people feel cool (air convection will take away the human body's heat), need to increase the clothing to keep warm, in the heat of the day, we will be sweating (evaporation), etc., F0808 uses far-infrared thermal sensors to detect the body surface temperature, and reported to the upper application, and then by the upper application to the cloud to analyze and monitor the data. F0808 uses far infrared heat sensor to detect the surface temperature of the human body, and report it to the upper application, which then passes it to the cloud for data analysis and monitoring.

Due to the monitoring of the human body's thermal radiation energy from the surface of the human body, in order to accurately monitor the temperature of the human body, so the installation of the equipment environment and the human body to be measured is a certain requirement, as follows.

1. As introduced in the above chapter, the same person in different states, the body temperature will exist within 1 degree of temperature change, such as intense exercise, or physiological or pregnancy, there will be differences, so the F0808 is only as a rapid screening of body temperature as an intelligent tool, not a medical testing equipment, the data can not be used as a medical final judgment, only for reference; such as found that the person who has a high fever, you can obtain the person and make a If you find a person with high fever, you can get the person and make an early warning, retest or measure the axillary or oral temperature for further screening.
2. Requirements for the measured personnel in the measurement before, maintain a stable mood, bare skin can not be exposed for a long time in the overheating (higher than the body

temperature) or too cold (far below the body temperature, such as 0 degrees) in the environment, the reason is that this kind of environment, the human skin through the air convection, or by the influence of radiation from the external heat source, the skin temperature has been deviated from the human body's normal body temperature, the F0808 monitoring the temperature value in the objective does not exist! The temperature value monitored by F0808 does not objectively exist, but it cannot truly reflect the body temperature of the person under test. If the person under test stays in a low or high temperature environment for a long period of time, it is necessary to return to normal before measurement.

3. Equipment assembly environment requires no strong heat source, or the existence of strong convection (wind, air conditioning wind), these factors will affect the body temperature of the person under test. Test environment temperature range is recommended in 10 ~ 30 within the best; more than the human body temperature of the environment, such as 37 degrees and above, the measured human body temperature data objectively does not have a problem, but no longer has the monitoring significance, in the environment of strong convection, the air will quickly take away the surface heat of the human body, resulting in the measured surface temperature of the human body is low, affecting the backend monitoring system on the temperature of the person being measured Misjudgment.
4. The installation place of the equipment needs to maintain ventilation and good heat dissipation structure and space, the equipment itself and the environment temperature difference is too large, will affect the measurement accuracy.